

Class 300 • Threaded Cap • Brass/Bronze Disc • Threaded Ends

76E Swing Check Valve

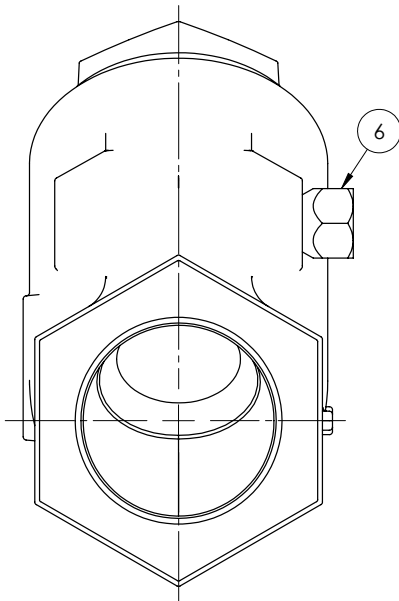
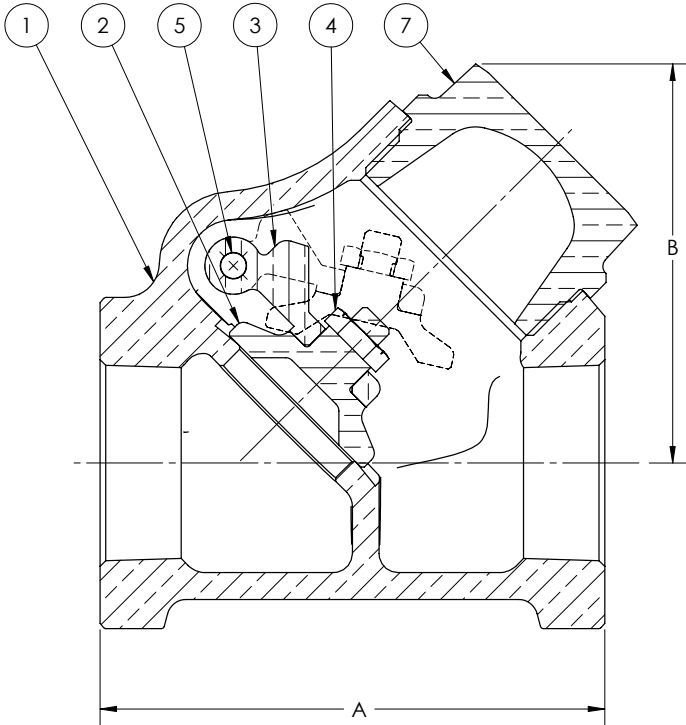

Materials of Construction

No.	Description	Material	ASTM Spec.
1	Body	Bronze	B-61 C92200
2	Disc	(1/4" - 3/4") Brass	B-16 H02
		(1" - 3") Bronze	B-61 C92200
3	Hinge	Bronze	B-584 C87600
4	Lock Nut	Brass	B-16 H02
5	Hinge Pin	Stainless Steel	A-276 C304
6	Hinge Pin Plug	Brass	B-16 H02
7	Cap	Bronze	B-61 C92200

Caution: Not recommended for use with reciprocating pumps or air compressors in liquid or gas services. See page 8 for Pressure-Temperature Ratings.

Industry Standards
MSS SP-80, Type 3

Dimensions and Weights
Inches (millimeters) - Pounds (kilograms)

Valve Size	Dimensions		Wt.
	B	A	
1/4	1.49	2.14	0.48
	(38)	(54)	(0.22)
3/8	1.49	2.14	0.46
	(38)	(54)	(0.21)
1/2	1.64	2.15	0.62
	(42)	(55)	(0.28)
3/4	1.92	2.71	1.10
	(49)	(69)	(0.50)
1	2.52	3.18	1.78
	(64)	(81)	(0.81)
1 1/4	2.95	3.81	2.68
	(75)	(97)	(1.22)
1 1/2	3.43	4.34	4.05
	(87)	(110)	(1.84)
2	4.19	5.11	6.67
	(106)	(130)	(3.03)
2 1/2	4.89	6.94	13.00
	(124)	(176)	(5.91)
3	5.88	8.39	21.67
	(149)	(213)	(9.85)