

**Class 150 • Threaded Cap • PTFE Disc • Threaded Ends**

**141TF Swing Check Valve**

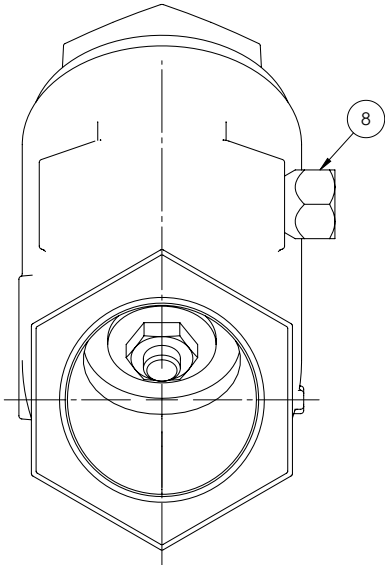
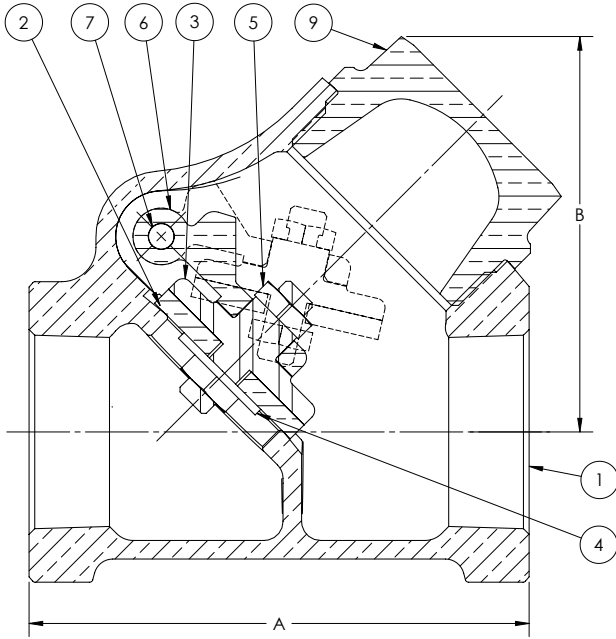

**Materials of Construction**

No.	Description	Material	ASTM Spec.
1	Body	Bronze	B-62 C83600
2	Disc	PTFE/15% Glass Filled	
3	Disc Holder	(1/2" - 3/4") Brass	B-16 H02
		(1" - 2") Bronze	B-62 C83600
4	Disc Washer	Brass	B-16 H02
5	Lock Nut	Brass	B-16 H02
6	Hinge	Bronze	B-584 C87600
7	Hinge Pin	Stainless Steel	A276 Type 304
8	Hinge Pin Plug	Brass	B-16 H02
9	Cap	Bronze	B-61 C92200

**Caution:** Not recommended for use with reciprocating pumps or air compressors in liquid or gas services.  
See page 8 for Pressure-Temperature Ratings.

Industry Standards
MSS SP-80, Type 4

**Dimensions and Weights**

Inches (millimeters) - Pounds (kilograms)

Valve Size	Dimensions		Wt.
	A	B	
1/2	2.19	1.64	0.70
	(56)	(42)	(0.32)
3/4	2.75	1.92	1.10
	(70)	(49)	(0.50)
1	3.23	2.45	1.80
	(82)	(62)	(0.82)
1 1/4	3.84	2.86	2.60
	(98)	(73)	(1.18)
1 1/2	4.40	3.42	3.90
	(112)	(87)	(1.77)
2	5.18	4.13	6.20
	(132)	(105)	(2.81)