

Features

- Range of products for vacuum service applications on vacuum breaking and roughing pumps
- Zero Minimum Operating Pressure Differential
- Elastomers de-gassed and cleaned ("VH" suffix)
- Mountable in any position, except as noted

Application

Conditions	Pressure
Low (and Rough)	760 to 25 Torr (or 29" Hg)
Medium (and Fine)	25 to 10 ⁻³ Torr
High	10 ⁻³ to 10 ⁻⁶ Torr
Very High	10 ⁻⁶ to 10 ⁻⁹ Torr
Ultra High	10 ⁻⁹ Torr and Below

Electrical

Standard Coil and Class of Insulation	Watt Rating and Power Consumption			Spare Coil Part No.	
	AC			General Purpose	Explosionproof
	Watts	VA Holding	VA Inrush	AC	AC
F	6.1	16	30	238210	238214
F	10.1	25	70	238610	238614
F	16.1	35	180	272610	272614
F	17.1	40	93	238610	238614

Standard Voltages: 24, 120, 240, 480 volts AC, 60 Hz (or 110, 220 volts AC, 50 Hz).
Must be specified when ordering. Other voltages, including DC, available when required.

Solenoid Enclosures

Standard: Watertight, Types 1, 2, 3, 3S, 4, and 4X.

Optional: Explosionproof and Watertight, Types 3, 3S, 4, 4X, 6, 6P, 7, and 9.
(To order, add prefix "EF" to catalog number.)

See *Optional Features Section* for other available options.

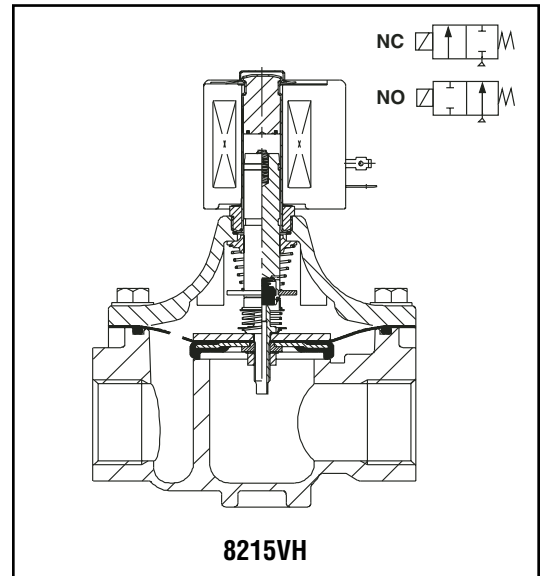
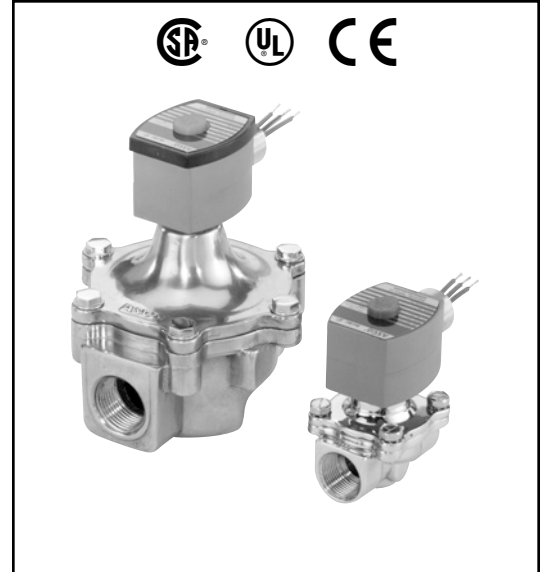

SPECIAL SERVICE VALVES

Nominal Ambient Temp. Ranges

Series 8262: 5°F to 131°F (-15°C to 55°C)

All Others: 32°F to 125°F (0°C to 52°C)

Note: Max. ambient for explosionproof (EF) is 125°F (52°C)

Refer to *Engineering Section* for details.

Approvals

8262 Series UL listed, CSA certified.

8210, 8030 Series CSA certified.

All Series meet applicable CE directives.

Refer to *Engineering Section* for details.

Specifications (English units)

Pipe Size (in)	Orifice Size (in)	Cv Flow Factor	Operating Pressure Differential (psi)		Body Material	Application Guide					Max. Fluid Temp. °F	Medium Vacuum to 10 ⁻³ Torr ③	High Vacuum to 10 ⁻⁶ Torr ③	Const. Ref.	Watt Rating/ Class of Coil Insulation ②
			Min.	Max.		Electrical Check	Breaker	Roughing	Foreline or High Vacuum	Suction or Release					
NORMALLY CLOSED (Closed when de-energized)															
1/8	1/8	0.35	0	15	Brass	●	●	●	●	●	180	-	8262H002VH ④	1	6.1/F
1/8	1/8	0.35	0	15	SS	●	●	●	●	●	180	-	8262H006VH ④	1	6.1/F
1/4	9/32	0.88	0	15	Brass	●	●	●	●	●	180	-	8262H090VH ④	2	6.1/F
1/4	9/32	0.88	0	15	SS	●	●	●	●	●	180	-	8262H038VH ④	2	6.1/F
3/8	3/8	1.8	0	15	Brass	●	●	●	●	●	180	8030G013VM	8030G013VH	3	10.1/F
1/2	7/16	2.8	0	15	Brass	●	●	●	●	●	180	8030G017VM	8030G017VH	4	16.1/F
3/4	3/4	5	0	4	Brass	●	-	-	-	-	180	8030G043VM	8030G043VH	5	17.1/F
3/4	3/4	5	0	15	Brass	-	●	-	-	●	180	8210G095VM	8210G095VH	6	10.1/F
1	1 5/8	20.5	0	15	Alum.	-	●	-	-	●	125	8215G050VM ①	8215G050VH ①	7	16.1/F
1 1/4	1 5/8	31.7	0	15	Alum.	-	●	-	-	●	125	8215G060VM ①	8215G060VH ①	7	16.1/F
1 1/2	1 5/8	32.7	0	15	Alum.	-	●	-	-	●	125	8215G070VM ①	8215G070VH ①	8	16.1/F
2	2 3/32	55	0	15	Alum.	-	●	-	-	●	125	8215G080VM ①	8215G080VH ①	9	16.1/F
NORMALLY OPEN (Open when de-energized)															
1/8	1/8	0.35	0	15	Brass	●	●	●	●	●	180	-	8262H129VH ④	10	10.1/F
1/8	1/8	0.35	0	15	SS	●	●	●	●	●	180	-	8262H237VH ④	10	10.1/F
1/4	9/32	0.96	0	15	Brass	●	●	●	●	●	180	-	8262H265VH ④	11	10.1/F
1/4	9/32	0.96	0	15	SS	●	●	●	●	●	180	-	8262H152VH ④	11	10.1/F
3/8	5/8	3	0	15	Brass	-	●	-	-	●	180	8210G033VM	8210G033VH	12	10.1/F
1/2	5/8	4	0	15	Brass	-	●	-	-	●	180	8210G034VM	8210G034VH	12	10.1/F
3/4	3/4	5.5	0	15	Brass	-	●	-	-	●	180	8210G035VM	8210G035VH	13	10.1/F
1	1 5/8	20.5	0	15	Alum.	-	●	-	-	●	125	8215G053VM ①	8215G053VH ①	14	16.1/F
1 1/4	1 5/8	31.7	0	15	Alum.	-	●	-	-	●	125	8215G063VM ①	8215G063VH ①	14	16.1/F
1 1/2	1 5/8	32.7	0	15	Alum.	-	●	-	-	●	125	8215G073VM ①	8215G073VH ①	15	16.1/F
2	2 3/32	55	0	15	Alum.	-	●	-	-	●	125	8215G083VM ①	8215G083VH ①	16	16.1/F

① Valves must be mounted with solenoid vertical and upright. ② On 50 hertz service, the rating for the 6.1/F solenoid is 8.1 watts.
③ For low vacuum applications to 29" Hg, use standard catalog valves with 0 psi minimum, 15+ psi maxium OPD (except 2" NPT). ④ FKM seals and disc

Specifications (Metric units)

Pipe Size (in)	Orifice Size (mm)	Kv Flow Factor (m3/h)	Operating Pressure Differential (bar)		Body Material	Application Guide					Max. Fluid Temp. °C	Medium Vacuum to 10 ⁻³ Torr ③	High Vacuum to 10 ⁻⁶ Torr ③	Const. Ref.	Watt Rating/ Class of Coil Insulation ②
			Min.	Max.		Electrical Check	Breaker	Roughing	Foreline or High Vacuum	Suction or Release					
NORMALLY CLOSED (Closed when de-energized)															
1/8	3.2	0.30	0	1	Brass	●	●	●	●	●	82	-	8262H002VH ④	1	6.1/F
1/8	3.2	0.30	0	1	SS	●	●	●	●	●	82	-	8262H006VH ④	1	6.1/F
1/4	7.1	0.76	0	1	Brass	●	●	●	●	●	82	-	8262H090VH ④	2	6.1/F
1/4	7.1	0.76	0	1	SS	●	●	●	●	●	82	-	8262H038VH ④	2	6.1/F
3/8	10	1.54	0	1	Brass	●	●	●	●	●	82	8030G013VM	8030G013VH	3	10.1/F
1/2	11	2.40	0	1	Brass	●	●	●	●	●	82	8030G017VM	8030G017VH	4	16.1/F
3/4	19	4.29	0	0.3	Brass	●	-	-	-	-	82	8030G043VM	8030G043VH	5	17.1/F
3/4	19	4.29	0	1	Brass	-	●	-	-	●	82	8210G095VM	8210G095VH	6	10.1/F
1	41	17.57	0	1	Alum.	-	●	-	-	●	52	8215G050VM ①	8215G050VH ①	7	16.1/F
1 1/4	41	27.17	0	1	Alum.	-	●	-	-	●	52	8215G060VM ①	8215G060VH ①	7	16.1/F
1 1/2	41	28.03	0	1	Alum.	-	●	-	-	●	52	8215G070VM ①	8215G070VH ①	8	16.1/F
2	53	47.14	0	1	Alum.	-	●	-	-	●	52	8215G080VM ①	8215G080VH ①	9	16.1/F
NORMALLY OPEN (Open when de-energized)															
1/8	3.2	0.30	0	1	Brass	●	●	●	●	●	82	-	8262H129VH ④	10	10.1/F
1/8	3.2	0.30	0	1	SS	●	●	●	●	●	82	-	8262H237VH ④	10	10.1/F
1/4	7.1	0.83	0	1	Brass	●	●	●	●	●	82	-	8262H265VH ④	11	10.1/F
1/4	7.1	0.83	0	1	SS	●	●	●	●	●	82	-	8262H152VH ④	11	10.1/F
3/8	16	2.57	0	1	Brass	-	●	-	-	●	82	8210G033VM	8210G033VH	12	10.1/F
1/2	16	3.43	0	1	Brass	-	●	-	-	●	82	8210G034VM	8210G034VH	12	10.1/F
3/4	19	4.71	0	1	Brass	-	●	-	-	●	82	8210G035VM	8210G035VH	13	10.1/F
1	41	17.57	0	1	Alum.	-	●	-	-	●	82	8215G053VM ①	8215G053VH ①	14	16.1/F
1 1/4	41	27.17	0	1	Alum.	-	●	-	-	●	52	8215G063VM ①	8215G063VH ①	14	16.1/F
1 1/2	41	28.03	0	1	Alum.	-	●	-	-	●	52	8215G073VM ①	8215G073VH ①	15	16.1/F
2	53	47.14	0	1	Alum.	-	●	-	-	●	52	8215G083VM ①	8215G083VH ①	16	16.1/F

① Valves must be mounted with solenoid vertical and upright. ② On 50 hertz service, the rating for the 6.1/F solenoid is 8.1 watts.
③ For low vacuum applications to 29" Hg, use standard catalog valves with 0 bar minimum, 1+ bar maxium OPD (except 2" NPT). ④ FKM seals and disc.

Dimensions inches (mm)

Const. Ref.		H	K	L	P	W
1	in	3.00	1.60	1.19	2.69	1.69
	mm	76	41	30	68	43
2	in	3.12	1.72	1.56	2.76	1.69
	mm	79	44	40	70	43
3	in	4.00	3.14	1.91	3.55	1.95
	mm	102	80	49	90	50
4	in	4.13	2.84	2.28	3.56	2.22
	mm	105	72	58	90	56
5	in	4.10	2.44	2.81	3.41	2.28
	mm	104	62	71	87	58
6	in	4.13	2.47	2.81	3.44	2.28
	mm	105	63	71	87	58
7	in	6.79	4.26	5.00	5.48	5.38
	mm	174	108	127	139	137
8	in	6.79	4.32	5.00	5.54	5.38
	mm	174	110	127	141	137
9	in	7.42	4.66	6.09	5.89	6.31
	mm	188	118	155	150	160
10	in	3.00	1.54	1.19	2.69	2.06
	mm	76	39	30	68	52
11	in	3.12	1.62	1.56	2.76	2.06
	mm	79	41	40	70	52
12	in	4.35	2.65	2.75	3.79	2.28
	mm	110	67	70	96	58
13	in	4.64	2.81	2.81	3.94	2.28
	mm	118	71	71	100	58
14	in	6.79	2.35	5.00	3.13	5.38
	mm	172	60	127	79	137
15	in	6.79	2.29	5.00	3.06	5.38
	mm	172	58	127	78	137
16	in	6.94	2.54	6.09	3.31	6.31
	mm	176	65	155	84	160

Const. Ref. 1, 2

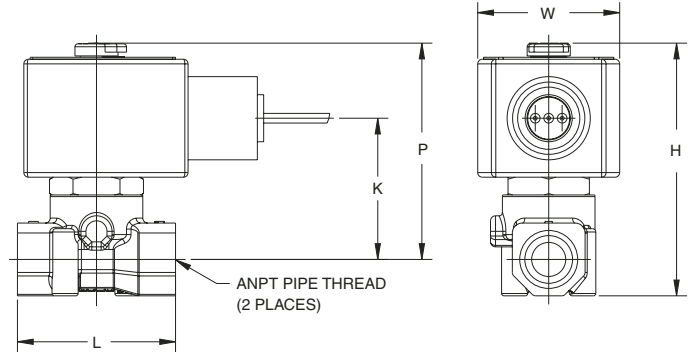

Const. Ref. 10, 11

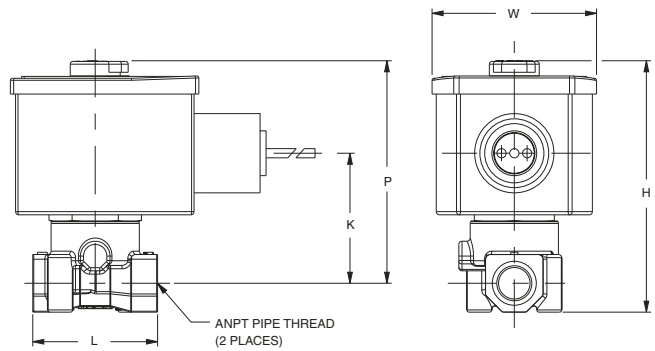

Const. Ref. 3

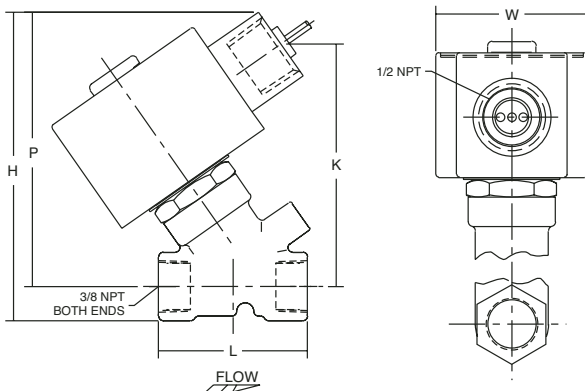

Const. Ref. 4

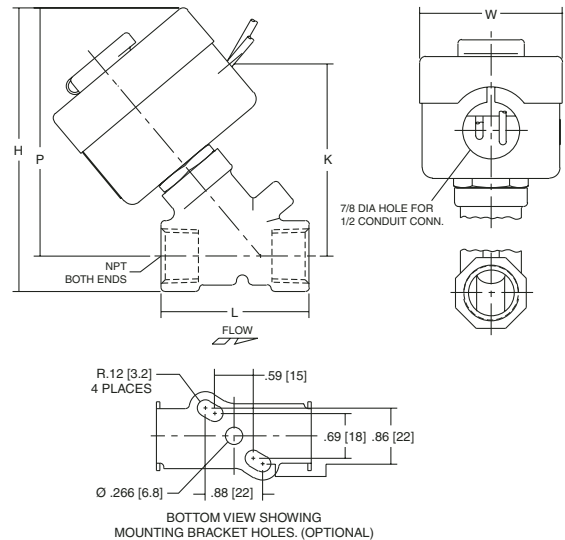

Dimensions inches (mm)

Const. Ref. 5, 6, 12, 13

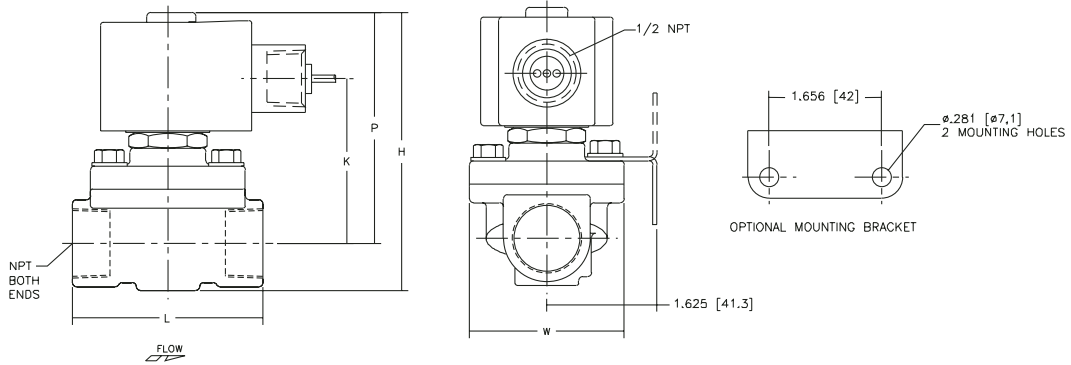

Const. Ref. 7,8, 9

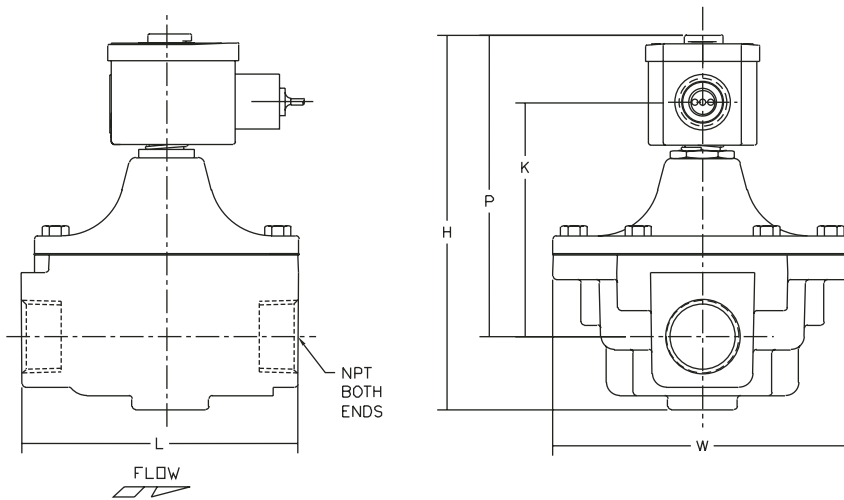

Const. Ref. 14, 15, 16

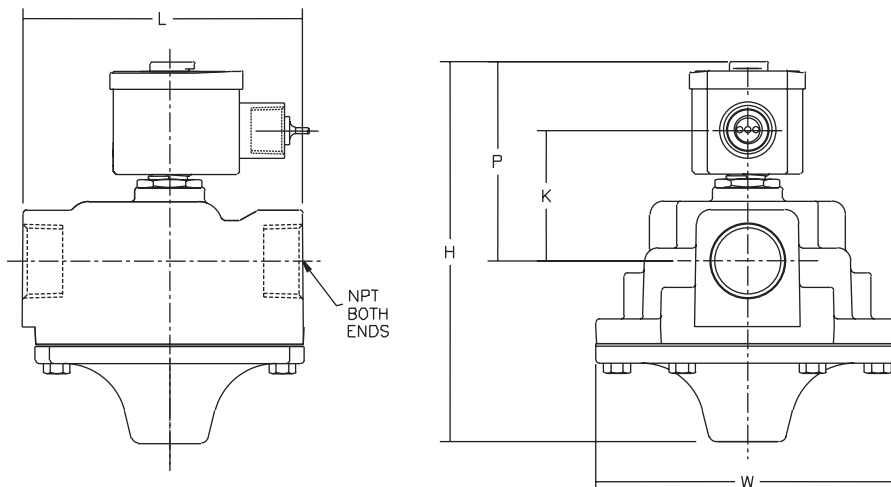

SPECIAL SERVICE VALVES