



# PVC & CPVC LAB BALL VALVES

LV-2-0804

## Laboratory and Specialty Valve



### Multi-Function 1/4" Lab Ball Valve with Adapter Kit

Kit includes PVC or CPVC 1/4" FIPT Valve, O-ring sealed male NPSM x MIPT Adapters, O-ring sealed male NPSM x 3/8" or 1/4" I.D. Tubing Adapters, EPDM or FKM O-rings and Hex Wrench for quick assembly of adapters with valve.

### Chemical and Corrosion Resistant PVC or CPVC Construction

Spears® Lab Valves never rust, scale or pit, providing exceptional chemical and corrosion resistance. Heat resistant CPVC allows higher temperature applications.

### EPDM or FKM O-ring Options

Choice of high grade, ozone resistant EPDM or FKM elastomer O-rings allows application specific selection for optimum chemical resistance.

### High Impact Polypropylene Handle

Features double stop engagement and exhibits excellent resistance to most chemical environments.

### PTFE Ball Seats

Spears® PTFE floating seat design reduces seat wear for extended valve life, smooth operation and bubble-tight shut-off. 100% factory tested.

### Full Schedule 80 Bore

In full open position, full bore virtually eliminates pressure drop, providing optimum flow.

### Full 150 psi Pressure Rating

Maximum Internal Pressure at 73° F for the most demanding applications.

### Suitable for Vacuum Service

Spears® Lab Valves are tested at 26 in. Hg vacuum for one hour with less than 1 in. Hg loss.

### Individual 1/4" and 3/8" Specialty Valves

Small, compact socket or thread design without adapters allows a variety of O.E.M. and other special applications.

This versatile, quarter-turn shut-off ball valve is ideally suited for a variety of laboratory, system monitoring and OEM applications. Available in IPS sizes 1/4" and 3/8" with choice of socket or threaded end connectors. Optional 1/4" valve & adapter kit provides multiple combinations of tubing and male pipe thread connections.



For additional information, please refer to Spears® THERMOPLASTIC VALVES & ACCESSORIES PRODUCT GUIDE & ENGINEERING SPECIFICATIONS V-4 and THERMOPLASTIC VALVES & ACCESSORIES Price Schedule V-1.

### Sample Engineering Specification

All thermoplastic valves shall be Lab type constructed from PVC Type I Cell Classification 12454 or CPVC Type IV Cell Classification 23447. All O-rings shall be EPDM, FKM. All valves shall have double stop Polypropylene handle. All 1/4" valves shall have optional field installable male threaded and tubing end connector adapters. All EPDM valves shall be certified by NSF International for use in potable water service. All valves shall be pressure rated at 150 psi for water at 73° F, as manufactured by Spears® Manufacturing Company.



FKM is a registered trademark of Dupont Dow Elastomers.

**PROGRESSIVE PRODUCTS FROM SPEARS® INNOVATION & TECHNOLOGY**

Visit our web site: [www.spearsmfg.com](http://www.spearsmfg.com)

## Quick-View Valve Selection Chart

Valve Size	O-ring Material	PVC Part Number <sup>1,2</sup>			Pressure Rating
		Socket	Threaded	Threaded with Kit	
1/4	EPDM	1522-002	1521-002	1529-002	150 psi Non-Shock Water @ 73° F
	FKM	1532-002	1531-002	1539-002	
3/8	EPDM	1522-003	1521-003	N/A	
	FKM	1532-003	1531-003	N/A	

1: For CPVC valves, add the "C" to part numbers listed (e.g., 1521-002C).  
 2: For valves with 1/4" I.D. tubing adapters, add the letter "A" to the part number listed (e.g., 1529-002A)

## Valve & Adapter Kit

Kit allows multiple connection options. Adapters use O-ring seals for easy connection to threaded valve.

Complete Kit includes:

- 1-Threaded 1/4" Valve
- 2-O-ring Sealed 1/4" MPT x Mipt Adapters
- 2-EPDM or FKM O-rings (AS568-013 size)
- 1-End Connector Wrench
  
- 2-O-ring Sealed 1/4" MPT x 3/8" I.D. Tubing Barb Adapters  
- OR -
- 2-O-ring Sealed 1/4" MPT x 1/4" I.D. Tubing Barb Adapters  
(Must Add "A" to Valve/Kit Part No.)

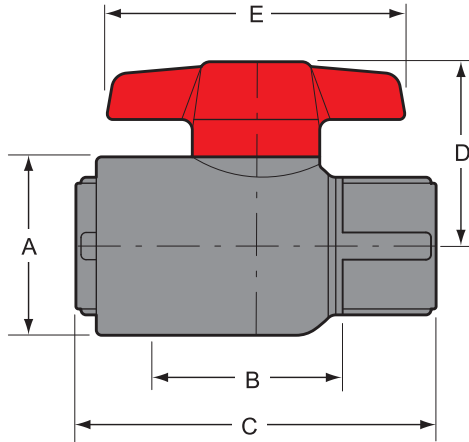

Basic Valve

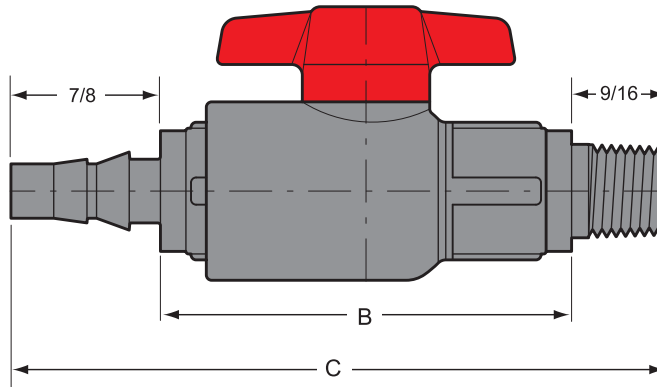

Valve with Adapter Kit

## Dimensions, Weights & Cv Values

Nominal Size	Dimension Reference (inches, ± 1/16)					Approx. Wt. (Lbs.)		C <sub>v</sub> <sup>2</sup> Values
	A	B <sup>1</sup>	C	D	E	PVC	CPVC	
1/4	1-1/16	15/16	2-1/8	1-1/16	1-3/4	.10	.11	10
1/4 w/Kit	1-1/16	2-7/16	3-7/8	1-1/16	1-3/4	.14	.15	6
3/8	1-5/16	1	2-3/16	1-1/4	2	.12	.13	24

1: Valve Lay Length

2: Gallons per minute at 1 psi pressure drop. Values calculated from valve laying length, based on derivative of Hazen-Williams equation with roughness factor of C=150.

## Temperature Pressure Rating

System Operating Temperature ° F (° C)		73 (23)	100 (38)	110 (43)	120 (49)	130 (54)	140 (60)	150 (66)	160 (71)	170 (77)	180 (82)	190 (88)
Valve Pressure Rating psi (MPa)	PVC	150 (1.03)	124 (.85)	100 (.69)	75 (.52)	-0- (-0-)	-0- (-0-)	-0- (-0-)	-0- (-0-)	-0- (-0-)	-0- (-0-)	-0- (-0-)
	CPVC	150 (1.03)	140 (.97)	130 (.90)	120 (.83)	110 (.76)	100 (.69)	90 (.62)	80 (.55)	70 (.48)	60 (.41)	-0- (-0-)



## SPEARS® MANUFACTURING COMPANY CORPORATE OFFICE

15853 Olden St., Sylmar, CA 91342 • PO Box 9203, Sylmar, CA 91392  
 (818) 364-1611 • www.spearsmfg.com

