

Class 125 • Bolted Bonnet • OS&Y • Bronze Trim • Flanged

351 Globe Valve

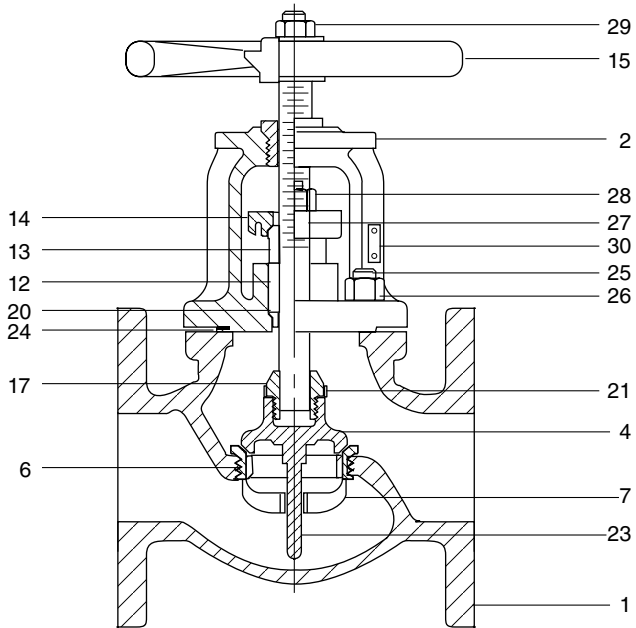

Materials of Construction

No.	Description	Material	ASTM
1	Body	Cast Iron	A126 Class B
2	Bonnet	Cast Iron	A126 Class B
4	Disc	Bronze (2" - 6")	B584 C84400
		Cast Iron (8" - 10")	A126 Class B
6	Body Seat Ring	Bronze	B584 C84400
7	Disc Seat Ring	Bronze (8" & 10")	B584 C84400
8	Stem	Manganese Bronze	B584 C86400
9	Yoke Bushing	Manganese Bronze	B584 C86400
12	Packing	Braided Flexible Graphite with Corrosion Inhibitor	
13	Gland	Brass (2" - 4")	B16 C36000
		Bronze (5" - 10")	B584 C84400
14	Gland Flange	Ductile Iron	A536 Gr. 65-45-12
15	Handwheel	Ductile Iron	A536 Gr. 65-45-12
17	Disc Stem Ring	Bronze	B584 C84400
20	Stem Hole Bushing	Brass	B16 C36000
21	Locking Device	18-8 SST Sheet (2" - 6")	A167
22	Disc Guide Stem*	Brass (8" & 10")	B16 C36000
23	Disc Guide Stem Pin	Brass (8" & 10")	B16 C36000
24	Bonnet Gasket	Aramid Fibers with SBR Binder	
25	Bonnet Studs	Steel	A108
26	Bonnet Stud Nuts	Steel	A563 Gr. A
27	Gland Studs	Naval Brass	B21 C48200
28	Gland Stud Nuts	Brass	B16 C36000
29	Handwheel Nut	Steel - Phos. Coated	A563 Gr. A
30	Identification Plate	Aluminum	

* Not shown

See page 5 for Pressure Temperature Ratings

Industry Standards

MSS SP-85, Type 1

Dimensions and Weights

Inches (millimeters) - Pounds (kilograms)

Valve Size	Dimensions			WT
	B	C	M	
2	11.12	8.00	8.00	35
	(282)	(203)	(203)	(15)
2 ½	11.50	8.00	8.50	40
	(292)	(203)	(216)	(18)
3	13.25	9.00	9.50	57
	(337)	(229)	(241)	(26)
4	15.50	10.00	11.50	95
	(394)	(254)	(292)	(43)
5	17.50	10.00	13.00	126
	(445)	(254)	(330)	(57)
6	19.50	12.00	14.00	176
	(495)	(305)	(356)	(80)
8	25.00	16.00	19.50	344
	(635)	(406)	(495)	(156)
10	30.50	18.00	24.50	570
	(775)	(457)	(622)	(259)

