

LEGEND:

GR: Powder Coated Supr-Green **EG:** Electro-Galvanized **PG:** Pre-Galvanized **AL:** Aluminum **HG:** Hot Dipped Galvanized **PL:** Plain **SS:** Stainless Steel **ZTC:** Zinc Trivalent Chromium
 For Stainless Steel (SS) and Zinc Trivalent Chromium (ZTC), refer to pages 86 and 87 in the Specialty Strut Section.

AS 0040D THRU AS 106P

EG, ZTC

CUSHION CLAMP ASSEMBLY

Material

Clamp: 1008-1018 Carbon Steel
 Cushion: Dupont Hytel
 Locknut: Nylon Insert
 Service Temperature:
 -65°F to 275°F.

Approvals

UL 2043 Fire Test for Heat and Visible Smoke Release
 25/50 Flame Spread/Smoke Development Index

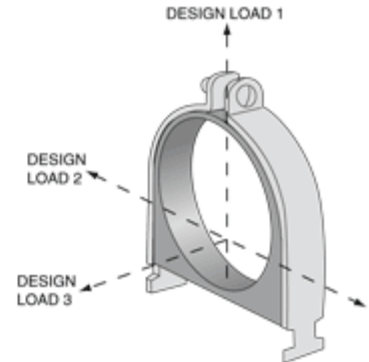
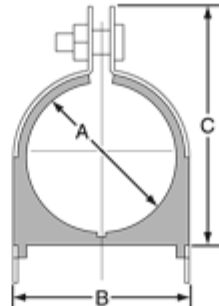
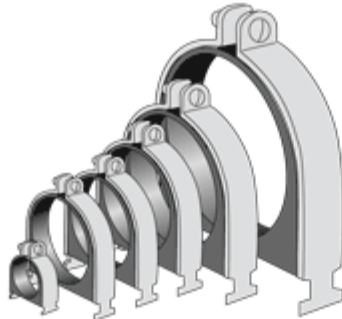

TUBE SERIES						
Part No.	O.D. Size	A	B	C	Std Pkg	Wt/100 pcs
AS 0040D	1/4"	0.25	0.62	0.98	25	10
AS 0060DN	3/8"	0.37	0.82	1.13	25	11
AS 0080DN	1/2"	0.50	0.94	1.34	25	13
AS 0100DN	5/8"	0.62	1.06	1.54	25	14
AS 0120DN	3/4"	0.75	1.20	1.68	25	14
AS 0140DN	7/8"	0.87	1.31	1.82	25	15
AS 0160D	1"	1.00	1.44	1.95	25	17
AS 0180DN	1 1/8"	1.12	1.57	2.08	20	18
AS 0200D	1 1/4"	1.25	1.70	2.21	20	18
AS 0220DN	1 3/8"	1.37	1.82	2.34	20	20
AS 0240D	1 1/2"	1.50	1.95	2.47	20	33
AS 0260DN	1 5/8"	1.62	2.07	2.60	20	35
AS 0280D	1 3/4"	1.75	2.20	2.73	20	37
AS 0320D	2"	2.00	2.45	3.04	10	41
AS 0340D	2 1/8"	2.12	2.57	3.23	10	46
AS 0400D	2 1/2"	2.50	2.94	3.79	10	49
AS 0420D	2 5/8"	2.62	3.07	3.92	5	51
AS 0480D	3"	3.00	3.57	4.42	5	57
AS 0500D	3 1/8"	3.12	3.57	4.42	5	60
AS 0580D	3 5/8"	3.62	4.20	5.11	5	70
AS 0660D	4 1/8"	4.12	4.57	5.54	5	94
AS 0820D	5 1/8"	5.12	5.57	6.54	5	125
AS 0980D	6 1/8"	6.12	6.57	7.54	5	130

TUBE SERIES			
Copper & Steel Tube O.D. Size	Design Load 1 (lbs)	Design Load 2 (lbs)	Design Load 3 (lbs)
1/4"	400	50	50
3/8"	400	50	50
1/2"	400	50	50
5/8"	400	50	50
3/4"	600	75	75
7/8"	600	75	75
1"	600	75	75
1 1/8"	600	75	75
1 1/4"	600	75	75
1 3/8"	600	75	75
1 1/2"	600	75	75
1 5/8"	600	75	75
1 3/4"	800	125	125
1 7/8"	800	125	125
2"	800	125	125
2 1/8"	800	125	125
2 1/4"	800	125	125
2 3/8"	800	125	125
2 1/2"	800	125	125
2 5/8"	800	125	125
3"	800	125	125
3 1/8"	800	125	125
3 5/8"	1000	200	150
4 1/8"	1000	200	150
6 1/8"	1000	200	150

PIPE SERIES						
Part No.	O.D. Size	A	B	C	Std Pkg	Wt/100 pcs
AS 009P	1/4" Pipe	0.54	0.98	1.34	25	13
AS 011P	3/8" Pipe	0.67	1.13	1.54	25	14
AS 014P	1/2" Pipe	0.84	1.29	1.82	25	15
AS 017P	3/4" Pipe	1.05	1.50	2.08	20	17
AS 021P	1" Pipe	1.31	1.76	2.34	20	19
AS 027P	1 1/4" Pipe	1.66	2.17	2.73	20	35
AS 0300DP	1 1/2" Pipe	1.90	2.35	2.86	20	39
AS 0380DP	2" Pipe	2.37	2.82	3.67	10	47
AS 0460DP	2 1/2" Pipe	2.87	3.32	4.17	5	55
AS 0560DP	3" Pipe	3.50	3.95	4.79	5	55
AS 0640DP	3 1/2" Pipe	4.00	4.45	5.42	5	88
AS 0720DP	4" Pipe	4.50	4.95	5.92	5	110
AS 089P	5" Pipe	5.56	6.01	6.92	5	130
AS 106P	6" Pipe	6.62	7.07	8.23	5	140

PIPE SERIES			
Pipe Sizes (Nominal)	Design Load 1 (lbs)	Design Load 2 (lbs)	Design Load 3 (lbs)
1/4"	400	50	50
3/8"	600	75	75
1/2"	600	75	75
3/4"	600	75	75
1"	600	75	75
1 1/4"	800	125	125
1 1/2"	800	125	125
2"	800	125	125
2 1/2"	800	125	125
3"	1000	200	150
3 1/2"	1000	200	150
4"	1000	200	150
5"	1000	200	150
6"	1000	200	150

Std Pkg & Wt/100 pcs: See chart above.