



77-100 Series Bronze Full Port Ball Valve



Threaded, 600 psig WOG, Cold Non-Shock. 150 psig Saturated Steam. (See referenced P/T chart)
Vacuum Service to 29 inches Hg.

Federal Specification: WW-V-35C, Type: II, Composition: BZ, Style: 3.

MSS SP-110; Ball Valves Threaded, Socket-Welding, Solder Joint, Grooved and Flared Ends.

FEATURES

- Two-piece body
- Reinforced seats
- Mounting pad for easy actuator mounting
- Blow-out-proof stem design
- Adjustable packing gland
- Full port for full flow & min. pressure drop

STANDARD MATERIAL LIST

- | | | | |
|-------------------|--|---------------|-------------------------|
| 1. Lever and grip | Steel, zinc plated w/vinyl | 10. Body seal | PTFE (1-1/4" to 2-1/2") |
| 2. Stem packing | MPTFE | 11. Body | B584-C84400 |
| 3. Stem bearing | RPTFE | | |
| 4. Ball | B16, chrome plated | | |
| 5. Seat (2) | RPTFE | | |
| 6. Retainer | B16 (1/4" to 1")
B584-C84400 (1-1/4" to 2-1/2") | | |
| 7. Gland nut | B16 | | |
| 8. Stem | B16 | | |
| 9. Lever nut | Steel, zinc plated | | |

VARIATIONS AVAILABLE:

- 77-140 Series (316 SS Ball & Stem)
77-190 Series (Locked Retainer)

OPTIONS AVAILABLE:

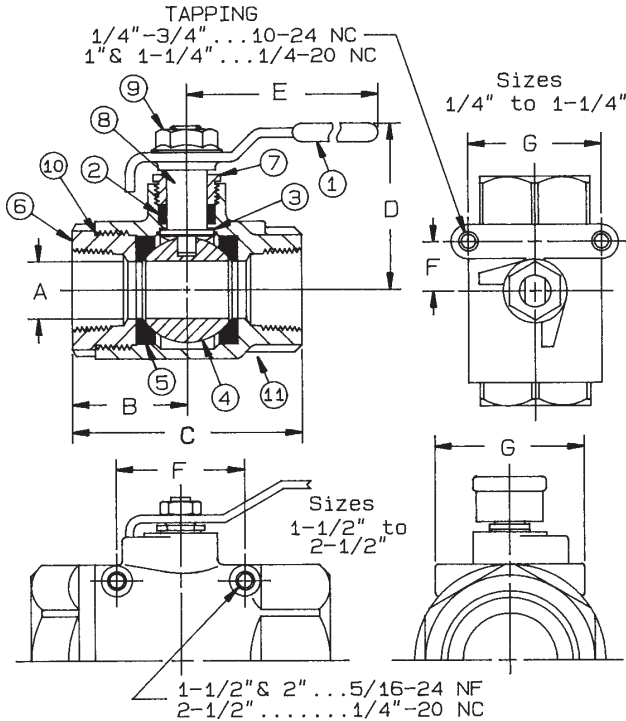

BRONZE FULL PORT BALL VALVE

NUMBER	SIZE	A	B	C	D	E	F	G	Wt.
77-101-01	1/4"	.43	1.09	2.18	1.77	3.87	.50	1.12	.79
77-102-01	3/8"	.50	1.09	2.18	1.77	3.87	.50	1.12	.75
77-103-01	1/2"	.50	1.09	2.18	1.77	3.87	.50	1.12	.69
77-104-01	3/4"	.81	1.56	3.12	2.17	4.87	.87	1.37	1.83
77-105-01	1"	1.00	1.81	3.62	2.68	5.50	.93	1.50	3.32
77-106-01	1-1/4"	1.25	2.12	4.25	2.90	5.50	.93	1.50	5.05
77-107-01	1-1/2"	1.50	2.37	4.75	3.10	8.00	2.08	3.06	6.71
77-108-01	2"	2.00	2.65	5.37	3.50	8.00	2.41	3.52	11.75
77-109-01	2-1/2"	2.50	3.25	6.50	4.06	8.00	2.75	3.37	17.25

(SUFFIX)	OPTION	SIZES
-02-	Stem Grounded	1/4" to 2-1/2"
-04-	2-1/4" CS Stem Extension	1/4" to 2-1/2"
-05-	Plain Ball	1/4" to 2-1/2"
-07-	Steel Tee Handle	1/4" to 1-1/4"
-08-	90° Reversed Stem	1/4" to 2-1/2"
-10-	SS Lever & Nut	1/4" to 2-1/2"
-11-	Therma-Seal™ Insulating Tee Handle	1/4" to 2"
-14-	Side Vented Ball (Uni-Directional)	1/4" to 2-1/2"
-15-	Wheel Handle, Steel	1/4" to 1-1/4"
-16-	Chain Lever - Vertical	3/4" to 2-1/2"
-17-	Rough Chrome Plated - Bronze Valves	1/4" to 2-1/2"
-18-	Plain Yellow Grip	1/4" to 2-1/2"
-20-	Slot Vented Ball	1/4" to 2-1/2"
-21-	UHMWPE Trim (Non-PTFE)	1/4" to 2-1/2"
-24-	Graphite Packing	1/4" to 2-1/2"
-27-	SS Latch-Lock Lever & Nut	1/4" to 2-1/2"
-28-	Mounting Pad Not Drilled & Tapped	1/4" to 2-1/2"
-30-	Cam-Lock and Grounded	1/4" to 1-1/4"
-32-	SS Tee Handle & Nut	1/4" to 1-1/4"
-35-	VTFE Trim	1/4" to 2-1/2"
-36-	SS High-Rise Round Handle & Nut	1/4" to 1-1/4"
-40-	Cyl-Loc and Grounded	1/4" to 1-1/4"
-45-	Less Lever & Nut	1/4" to 2-1/2"
-46-	Latch Lock Lever - Lock in Closed Position Only	1/4" to 2-1/2"
-47-	SS Oval Latch-Lock Handle & Nut	1/4" to 3/4"
-48-	SS Oval Handle (No Latch) & Nut	1/4" to 2"
-49-	Assembled Dry	1/4" to 2-1/2"
-50-	2-1/4" CS Locking Stem Extension	1/4" to 2-1/2"
-56-	Multifill Seats & Packing	1/4" to 2-1/2"
-57-	Oxygen Cleaned	1/4" to 2-1/2"
-58-	Chain Lever - Horizontal	3/4" to 2-1/2"
-60-	Static Grounded Ball & Stem	1/4" to 2-1/2"
-63-	NPT x Solder/Socket Weld	1/4" to 2-1/2"
-64-	250# Steam Trim	1/4" to 2-1/2"
-92-	Balancing Stop	1/4" to 2-1/2"
-P01-	BSPP (Parallel) Thread Connection	1/4" to 2-1/2"
-T01-	BSPT (Tapered) Thread Connection	1/4" to 2-1/2"
-SV-	Safety Vent (H-12)	1/4" to 2"

**For Pressure/Temperature Ratings,
Refer to Page M-8, Graph No. 4**

FLOW DATA

For Apollo® Ball Valves

The listed Cv “factors” are derived from actual flow testing, in the Apollo® Ball Valve Division, Conbraco Industries, Inc., Pageland, South Carolina. These tests were completed using standard “off the shelf” valves with no special preparation and utilizing standard schedule 40 pipe. It should be understood that these factors are for the valve only and also include the connection configuration. The flow testing is done utilizing water as a fluid media and is a direct statement of the gallons of water flowed per minute with a 1 psig pressure differential across the valve/connection unit. Line pressure is not a factor. Because the Cv is a factor, the formula can be used to estimate flow of most media for valve sizing.

Flow of Liquid

$$Q = Cv \sqrt{\frac{\Delta P}{SpGr}}$$

$$\text{or } \Delta P = \frac{(Q)^2 (SpGr)}{(Cv)^2}$$

Where:

Q = flow in US gpm
 ΔP = pressure drop (psig)
 SpGr = specific gravity at flowing temperature
 Cv = valve constant

Flow of Gas

$$Q = 1360 Cv \sqrt{\frac{(\Delta P) (P_1)}{(SpGr) (T)}}$$

$$\text{or } \Delta P = \frac{5.4 \times 10^{-7} (SpGr) (T) (Q)^2}{(Cv)^2 (P_2)}$$

Where:

Q = flow in SCFH
 ΔP = pressure drop (psig)
 SpGr = specific gravity (based on air = 1.0)
 P₂ = outlet pressure—psia (psig + 14.7)
 T = (temp. °F + 460)
 Cv = valve constant

Cv FACTORS FOR APOLLO VALVES

Valve Size (inches)	1/4	3/8	1/2	3/4	1	1-1/4	1-1/2	2	2-1/2	3	4	6	8	10	12
Ball Valves															
32-100/200 Series	5.1	6.6	8	24	30	45	55	95	--	--	--	--	--	--	--
64-100/200 Series	6	7	19	34	50	104	268	309	629	1018	1622	--	--	--	--
64W Series	--	--	--	--	--	--	--	--	629	1018	1622	--	--	--	--
70B-140 Series	8.4	7.2	15	30	43	48	84	108	190	370	670	--	--	--	--
70-100/200 Series	8.4	7.2	15	30	43	48	84	108	190	370	670	--	--	--	--
70-300/400 Series	--	--	26	48	65	125	170	216	--	--	--	--	--	--	--
70-600 Series	2.3	4.5	5.4	12	14	21	34	47	--	--	--	--	--	--	--
70-800 Series	8.4	7.2	15	30	43	48	84	--	--	--	--	--	--	--	--
71AR Series	--	--	--	30	43	48	84	108	190	370	--	--	--	--	--
71-100/200 Series	--	--	--	30	43	48	84	108	190	370	--	--	--	--	--
72-100/900 Series	--	--	26	48	65	125	170	216	--	--	--	--	--	--	--
73A-100 Series	8.4	7.2	15	30	43	48	84	108	--	--	--	--	--	--	--
73-300/400 Series	--	--	26	48	65	125	170	216	--	--	--	--	--	--	--
74-100 Series	8.4	7.2	15	30	43	48	84	108	190	370	670	--	--	--	--
75-100 Series	8.4	7.2	15	30	43	48	84	108	190	370	670	--	--	--	--
76AR Series	8.4	7.2	15	30	43	48	84	108	190	370	670	--	--	--	--
76F-100 Series	8.1	15	15	51	68	125	177	389	--	--	--	--	--	--	--
76-100 Series	8.4	7.2	15	30	43	48	84	108	190	370	--	--	--	--	--
76-300/400 Series	--	--	26	48	65	125	170	216	--	--	--	--	--	--	--
76-600 Series	2.3	4.5	5.4	12	14	21	34	47	--	--	--	--	--	--	--
7K-100 Series	--	--	15	51	68	125	177	389	503	--	--	--	--	--	--
77AR Series	8.1	15	15	51	68	125	177	389	--	--	--	--	--	--	--
77C-100/200 Series	4.5	7.2	16	36	68	125	177	389	503	--	--	--	--	--	--
77D-140 Series	4.5	7.2	16	36	68	125	177	389	--	--	--	--	--	--	--
77D-640 Series	--	--	--	11	24	35	--	--	--	--	--	--	--	--	--
77G-UL Series	4.5	7.2	16	36	68	125	177	389	503	--	--	--	--	--	--
77W Series	--	--	16	36	68	125	177	389	--	--	--	--	--	--	--
77X Series	--	--	16	36	68	--	--	--	--	--	--	--	--	--	--
77-100/200 Series	8.1	15	15	51	68	125	177	389	503	--	--	--	--	--	--

Cv FACTORS FOR APOLLO VALVES

Valve Size (inches)	1/4	3/8	1/2	3/4	1	1-1/4	1-1/2	2	2-1/2	3	4	6	8	10	12
Ball Valves															
79 Series	8.5	8.5	9.8	32	44	66	148	218	440	390	--	--	--	--	--
80/81 Series	8.4	7.2	15	30	43	48	84	108	190	370	--	--	--	--	--
82-100/200 Series	8.1	14	26	51	68	120	170	376	510	996	1893	--	--	--	--
83A/83B Series	8.1	14	26	51	68	120	170	376	--	--	--	--	--	--	--
83R-100/200 Series	--	--	--	--	--	--	170	376	--	996	1893	--	--	--	--
86A/86B Series	8.1	14	26	51	68	120	170	376	--	--	--	--	--	--	--
86R-100/200 Series	--	--	--	--	--	--	170	376	--	996	1893	--	--	--	--
87A-100 Series	--	--	--	--	--	--	86	104	234	375	673	1099	1902	3890	--
87A-200 Series	--	--	15	19	75	--	195	410	545	1021	2016	4837	9250	15170	22390
87A-700 Series	--	--	--	--	--	--	86	104	234	375	673	1099	1902	3890	--
87A-900 Series	--	--	15	19	75	--	195	410	545	1021	2016	4837	9250	15170	22390
87B-100 Series	--	--	--	--	--	--	86	104	234	375	673	1099	1902	3890	--
88A-100 Series	--	--	--	--	--	--	86	104	234	375	673	1099	1902	3890	--
88A-200 Series	--	--	15	19	75	--	195	410	545	1021	2016	4837	9250	15170	22390
88A-700 Series	--	--	--	--	--	--	86	104	234	375	673	1099	1902	3890	--
88A-900 Series	--	--	15	19	75	--	195	410	545	1021	2016	4837	9250	15170	22390
88B-100 Series	--	--	--	--	--	--	86	104	234	375	673	1099	1902	3890	--
89-100 Series	8.4	7.2	15	30	43	48	84	108	190	370	--	--	--	--	--
9A-100 Series	8.3	6.7	5.7	10	16	25	40	62	--	--	--	--	--	--	--
91-100 Series	8.3	6.7	5.7	10	16	25	40	62	--	--	--	--	--	--	--
92-100 Series	8.3	6.7	5.7	10	16	25	40	62	--	--	--	--	--	--	--
93-100 Series	8.3	6.7	5.7	10	16	25	40	62	--	--	--	--	--	--	--
94A-100/200 Series	6	7	19	34	50	104	268	309	629	1018	1622	--	--	--	--
95-100/200 Series	--	--	15	51	68	--	--	--	--	--	--	--	--	--	--
95A-300/400 Series	--	--	19	34	50	--	--	--	--	--	--	--	--	--	--
96-100 Series	8.3	6.7	5.7	10	16	25	40	62	--	--	--	--	--	--	--
399-100 Series	8.4	7.2	15	30	43	48	84	108	190	370	--	--	--	--	--
489-100 Series	8.4	7.2	15	30	43	48	84	108	190	370	--	--	--	--	--

400# Bronze P-T Rating (Graph 3)

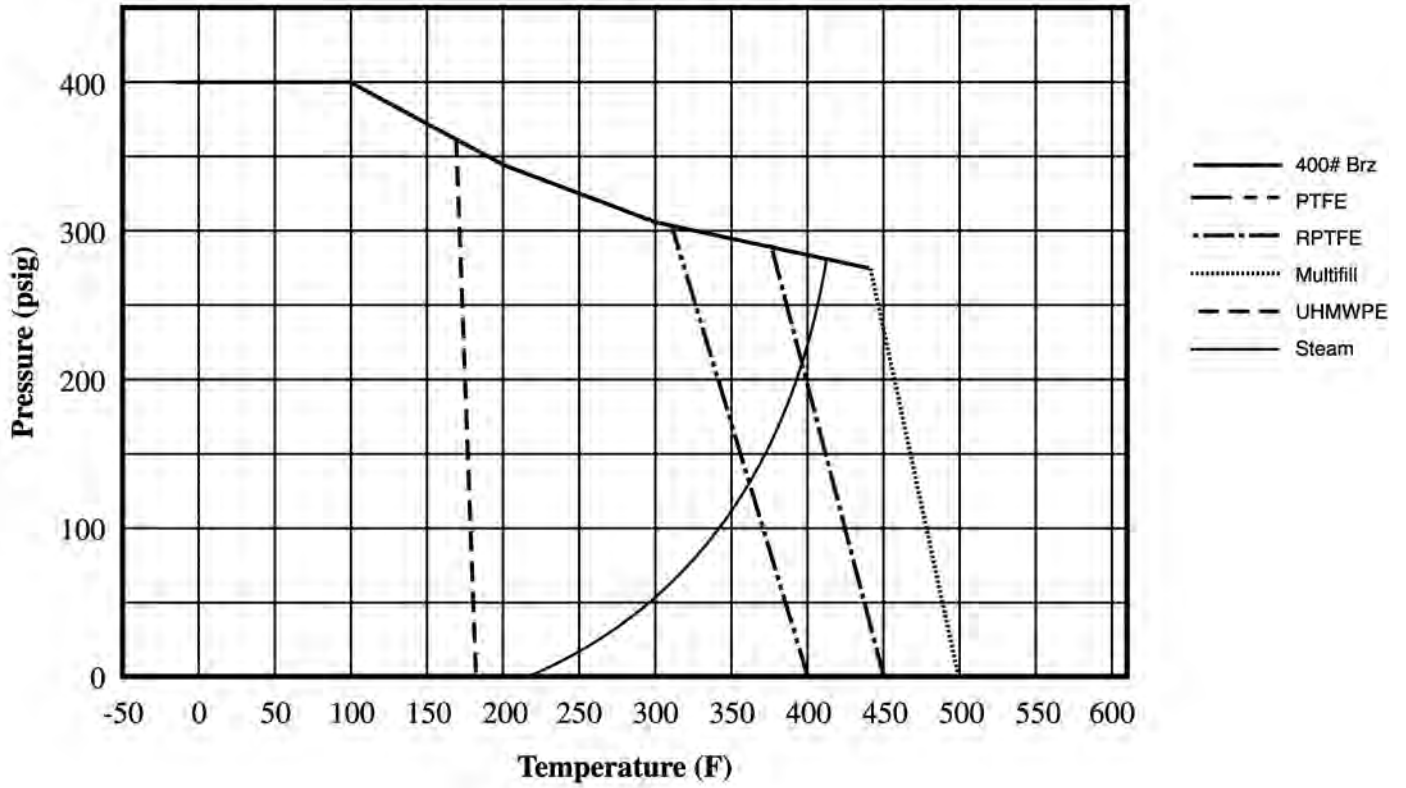

600# Bronze P-T Rating (Graph 4)

