

NON-ELECTRIC CONDENSATE PUMPS

PMPM CAST IRON MINI-PUMP

Pressure Motive Pump

Watson McDaniel reserves the right to change the designs and/or materials of its products without notice.
©2010 Watson McDaniel Company

PUMPS

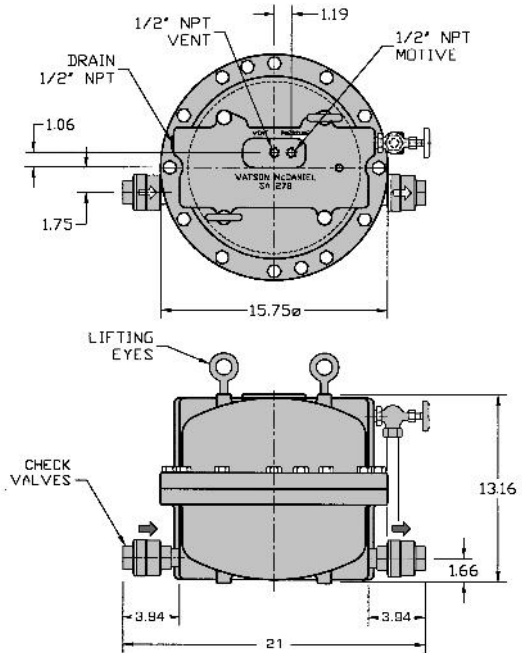
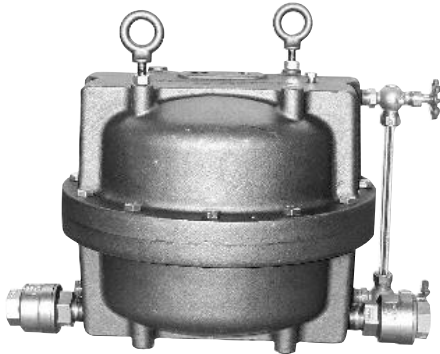

Model	PMPM
Body	Cast Iron
Cover	Cast Iron
Sizes	1", 1 1/4"
Check Valves	Stainless Steel
PMO Max. Operating Pressure	150 PSIG
TMO Max. Operating Temperature	366°F
PMA Max. Allowable Pressure	150 PSIG @ 450°F

TYPICAL APPLICATIONS

The Model **PMPM** pressure motive pump has an *extremely low profile*. These low-profile tanks are required when draining condensate from process equipment positioned close to the ground which limits the filling head of the pump.

FEATURES

- Mechanism incorporates **heat-treated stainless steel wear items** for extended service life
- All stainless steel internals for ultimate corrosion resistance
- Dual springs made from **Inconel-X-750** for high-temperature corrosive service
- Operates using steam, air, nitrogen or other pressurized gases as the motive force
- Low-profile design
- **Non-Electric** – can be used in remote locations or NEMA 4, 7, 9 & hazardous areas

MATERIALS

Body & Cover	Cast Iron
Cover Gasket	Garlock
Cover Bolts	Steel
Inlet Valve	Hardened Stainless Steel 40 Rc
Vent Valve	Hardened Stainless Steel 40 Rc
Mechanism Yoke	304 Stainless Steel
Ball Float	304 Stainless Steel
Check Valves	Stainless Steel
Springs	Inconel-X-750
Other Internal Components	Stainless Steel

CAPACITIES – Condensate (lbs/hr)

Motive Pressure (PSIG)	Back Pressure (PSIG)	6" Filling Head			
		Steam Motive		Air Motive	
		1"	1 1/4"	1"	1 1/4"
25	15	1200	1800	1720	2580
25	5	1970	2955	2265	3398
50	40	1200	1800	1640	2460
50	25	1480	2220	1980	2970
50	15	1860	2790	2220	3330
50	5	2240	3360	2485	3728
75	60	1160	1740	1935	2903
75	40	1640	2460	2185	3278
75	25	1960	2960	2340	3510
100	60	1415	2122	2020	3030
100	40	1825	2732	2280	3420
100	25	1985	2977	2420	3630
100	15	2175	3262	2455	3683
150	100	1120	1680	1456	2184
150	80	1220	1830	1525	2288
150	60	1570	2355	1885	2828

SIZING

The capacity of the **PMPM** is based on the inlet steam pressure, the system back pressure, and the amount of filling head available. The trap used in a pump-trap combination must be sized to handle the instantaneous discharge of the pump.

Choose a F&T trap that will pass the condensate load at a 1/4 PSI differential pressure. The PMO of the steam trap must be higher than the motive inlet steam pressure. Consult factory for proper choice of steam trap.