

Class 200 • Union Bonnet* • Rising Stem • Threaded Ends

422 Gate Valve

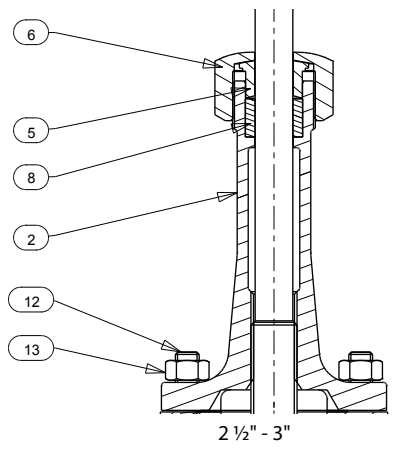
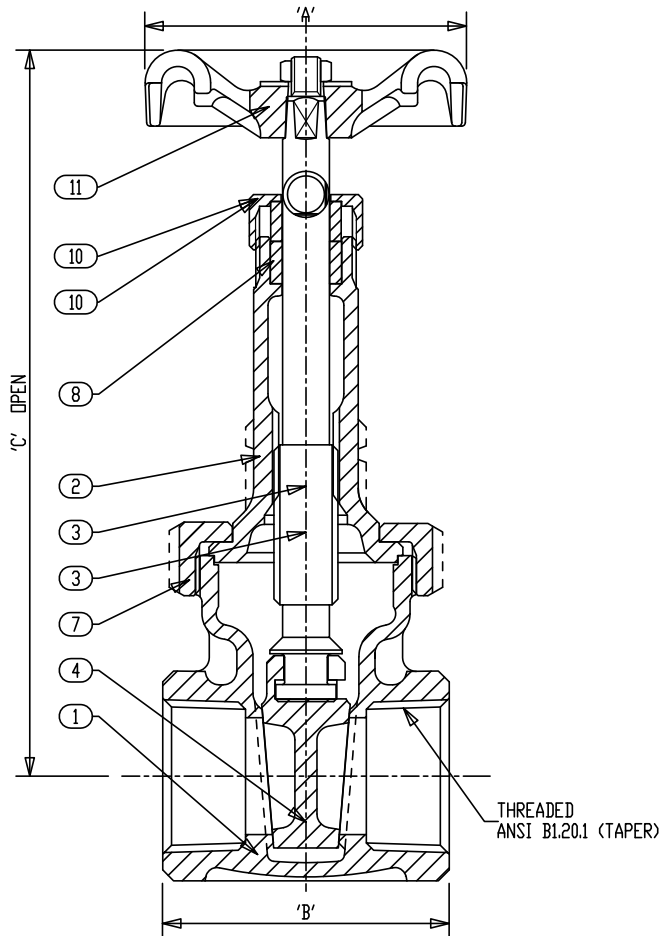

Materials of Construction

No.	Description	Material	ASTM Spec.
1	Body	Bronze	B-62 C83600
2	Bonnet - Union	Bronze	B-62 C83600
3	Stem	Copper Silicon Bronze	B-371 C69400
4	Disc	Bronze	B-62 C83600
5	Gland	Brass	BSEN12164 CW614N
6	Packing Nut	Bronze	B-62 C83600
7	Union Ring	Bronze	B-62 C83600
8	Packing Ring	Graphite (Asbestos Free)	WRAS Listed & Approved
10	Packing Nut	(1/4" - 2") Brass (2 1/2" - 3") Bronze	BSEN12164 CW614N B-62 C83600
11	Handwheel	Malleable Iron	A-197 F22000
12	Bonnet Stud	Phosphated Steel	BS970605M36 T & BS3189
13	Bonnet Nut	Phosphated Steel	BS4190 & BS3189
14	Gasket**	(2 1/2" - 3" only) Synthetic Glass Fiber Nitrile Filled	Klingersil C4500

** Not Shown
See page 8 for Pressure-Temperature Ratings.

Industry Standards	
MSS SP-80, Type 2	

Dimensions and Weights
Inches (millimeters) - Pounds (kilograms)

Valve Size	Dimensions			Wt.
	C	A	B	
1/4	4.96	1.75	1.81	0.7
	(126)	(45)	(46)	(0.32)
3/8	4.96	1.75	1.81	0.7
	(126)	(45)	(46)	(0.31)
1/2	5.07	2.06	1.98	1.0
	(129)	(52)	(51)	(0.46)
3/4	6.25	2.56	2.14	1.6
	(159)	(65)	(55)	(0.72)
1	7.44	2.75	2.46	2.4
	(189)	(70)	(63)	(1.10)
1 1/4	8.62	3.06	2.77	3.3
	(219)	(78)	(71)	(1.50)
1 1/2	9.68	3.62	2.85	4.9
	(246)	(92)	(73)	(2.25)
2	11.85	3.62	3.25	7.0
	(301)	(92)	(83)	(3.20)
2 1/2	14.53	5.28	4.72	12.8
	(369)	(134)	(120)	(5.80)
3	16.39	5.28	5.28	18.8
	(416)	(134)	(134)	(8.52)

* 2 1/2" and 3" have Bolted Bonnet