

**Class 300 • Outside Screw & Yoke • Flexible Wedge Disc**

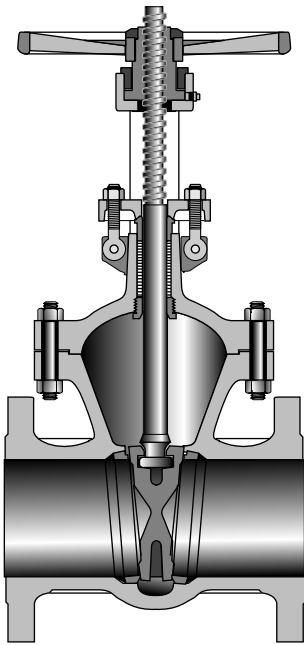

**Figure 33**

Gate, Flanged

**Figure 33½**

Gate, Butt Weld

**Size Range:**

2 through 24 inches  
(50 - 600 mm)

**Pressure Temperature Rating**

Carbon Steel  
ASTM A216 Grade WCB  
740 psi @ -20°F to 100°F  
(51 bar @ -28°C to 37°C)

**Material of Construction\***

Description	Material
Body	WCB
Bonnet	WCB
Seat Rings	Hardfaced
Disc	CA-15 or 13% CR Overlay
Stem	410 SS
Packing	Graphite
Bonnet Gasket	Stainless Steel spiral wound Graphite
Back Seat	410 SS
Yoke Sleeve	D2 Ni-Resist
Retaining Nut	Malleable or Steel
Gland	Steel
Gland Flange	Steel
Eye Bolt	Steel
Eye Bolt Nuts	Steel
Pins	Steel
Bonnet Studs	A193 Gr. B7
Bonnet Nuts	A194 Gr. 2H
Handwheel	Malleable, Ductile or Steel
Handwheel Nut	Ductile or Steel
I.D. Tags	SS
I.D. Pins	Steel
Spacer	Steel
Grease Fittings	Steel

**Industry Standards**

Steel Valves	ASME B16.34
Face-to-Face/End-to-End	ASME B16.10
Flange Dimensions	ASME B16.5
Weld End	ASME B.16.25
Basic Design	API 600
Testing	API 598

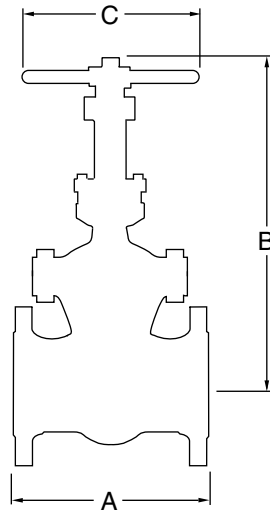

**NOTES:**

\*Standard construction: WCB-Trim 8, other options are available. Crane recommends the use of manual or powered gear assistance for sizes 8" and larger.

**Dimensions and Weights**

Inches (millimeters) - pounds (kilograms)

Valves	2 (50)	2 ½ (65)	3 (80)	4 (100)	6 (150)	8 (200)	10 (250)	12 (300)	14 (350)	16 (400)	18 (450)	20 (500)	24 (600)
A	8.50 (216)	9.50 (241)	11.12 (282)	12.00 (305)	15.88 (403)	16.50 (419)	18.00 (457)	19.75 (502)	30.00 (762)	33.00 (838)	36.00 (914)	39.00 (990)	45.00 (1143)
B (Open)	18 (457)	18 (457)	21 (533)	24 (609)	33 (838)	42 (1066)	50 (1270)	58 (1473)	62 (1574)	71 (1803)	79 (2006)	85 (2154)	100 (2540)
C	8 (203)	8 (203)	9 (229)	10 (254)	14 (356)	16 (406)	18 (457)	20 (508)	22 (559)	24 (610)	25 (635)	30 (762)	30 (762)
Wt. (33)	69 (31)	77 (34)	112 (50)	165 (74)	310 (140)	500 (226)	760 (344)	1050 (476)	1530 (693)	2380 (1079)	2722 (1234)	3650 (1655)	5115 (2320)
Wt. (33½)	57 (25)	64 (29)	92 (41)	132 (59)	256 (116)	410 (185)	650 (294)	880 (399)	1530 (693)	2380 (1079)	2000 (907)	3370 (1528)	4675 (2120)