

# Class 300 • Outside Screw & Yoke • Bolted Bonnet

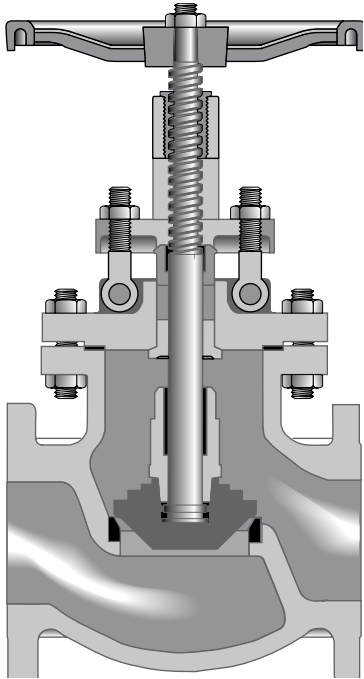

**Figure 151**  
Globe, Flanged  
**Figure 151½**  
Globe, Butt Weld

**Size Range:**  
2 through 12 inches  
(50 - 300 mm)

**Pressure Temperature Rating**  
Carbon Steel  
ASTM A216 Grade WCB  
740 psi @ -20°F to 100°F  
(51 bar @ -28°C to 37°C)

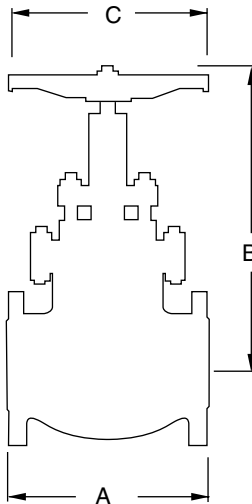

## Industry Standards

Steel Valves	ASME B16.34
Face-to-Face/End-to-End	ASME B16.10
Flange Dimensions	ASME B16.5
Weld End	ASME B.16.25
Testing	API 598

## Material of Construction\*

Description	Material
Body	WCB
Bonnet	WCB
Seat Rings	Hardfaced
Disc	13% CR Overlay
Stem	410 SS
Packing	Graphite
Bonnet Gasket	Stainless Steel spiral wound Graphite
Back Seat	410 SS
Disc Stem Nut	410 SS
Disc Washer	Carbon Steel
Gland	410 SS
Gland Flange	WCB
Eye Bolt	Steel
Eye Bolt Nuts	A563 Gr. A or O
Pins	-
Bonnet Studs	A193 Gr. B7
Bonnet Nuts	A194 Gr. 2H
Handwheel	WCB
Handwheel Nut	A194 Gr. 2H
I.D. Tags	SS
I.D. Pins	Steel

### NOTES:

\*Standard construction: WCB-Trim 8, other options are available. Crane recommends the use of manual or powered gear assistance for sizes 6" and larger.

## Dimensions and Weights

Inches (millimeters) - pounds (kilograms)

Valves	2 (50)	2½ (65)	3 (80)	4 (100)	6 (150)	8 (200)	10 (250)	12 (300)
A	10.50 (267)	11.50 (292)	12.50 (317)	14.00 (356)	17.50 (444)	22.00 (558)	24.50 (622)	28.00 (711)
B (Open)	15 (381)	18 (457)	18 (457)	21 (533)	25 (635)	36 (914)	41 (1041)	51 (1295)
C	8 (203)	10 (254)	10 (254)	14 (355)	18 (457)	22 (559)	24 (610)	25 (635)
Wt. (151)	69 (31)	99 (44)	128 (58)	190 (86)	330 (149)	330 (149)	700 (317)	1360 (616)
Wt. (151½)	62 (28)	73 (33)	124 (56)	181 (82)	340 (154)	530 (240)	710 (322)	1400 (635)