

Class 150 • Bolted Cap

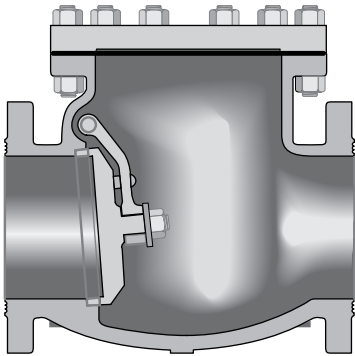

Figure 147
Swing Check, Flanged

Figure 147½
Swing Check, Butt Weld

Size Range:
2 through 24 inches
(50 - 600 mm)

Pressure Temperature Rating
Carbon Steel
ASTM A216 Grade WCB
285 psi @ -20°F to 100°F
(20 bar @ -28°C to 37°C)

Material of Construction*

Description	Material
Body	WCB
Cap	WCB
Seat Ring	Hardfaced
Disc	13% CR Overlay
Hinge	WCB
Pins, Hinge	410 SS
Disc Washer	Steel
Cap Screw	A307 Gr. B
Cap Gasket	Corrugated Soft Steel or Steel/ Stainless Steel w/Graphite
Cap Studs	A193 Gr. B7
Cap Nuts	A194 Gr. 2H
I.D. Tags	SS
I.D. Pins	Steel

NOTE:

*Standard construction: WCB-Trim 8, other options are available.

Industry Standards

Steel Valves	ASME B16.34
Face-to-Face/End-to-End	ASME B16.10
Flange Dimensions	ASME B16.5
Weld End	ASME B.16.25
Testing	API 598

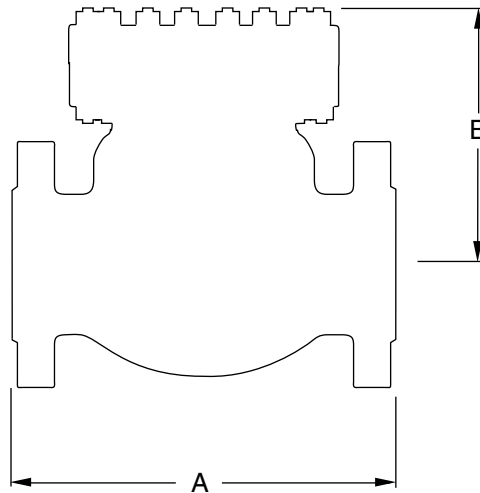

Dimensions and Weights

Inches (millimeters) - pounds (kilograms)

Valves	2 (50)	2 ½ (65)	3 (80)	4 (100)	6 (150)	8 (200)	10 (250)	12 (300)	14 (350)	16 (400)	18 (450)	20 (500)	24 (600)
A	8.00 (203)	8.50 (216)	9.50 (241)	11.50 (292)	14.00 (356)	19.50 (495)	24.50 (622)	27.50 (698)	31.00 (787)	34.00 (863)	38.50 (977)	38.50 (977)	51.00 (1295)
B (Open)	9 (229)	7 (178)	7 (178)	9 (229)	11 (279)	13 (330)	15 (381)	17 (432)	15 (381)	17 (432)	18 (457)	19 (482)	22 (558)
Wt. (147)	41 (18)	57 (25)	64 (29)	101 (45)	170 (77)	360 (163)	485 (219)	765 (346)	950 (430)	1225 (555)	1700 (771)	1850 (839)	2600 (1179)
Wt. (147½)	42 (19)	57 (25)	64 (29)	101 (45)	170 (77)	360 (163)	485 (219)	807 (366)	950 (430)	1225 (555)	1700 (771)	1850 (839)	2600 (1179)