

Class 150 • Outside Screw & Yoke • Bolted Bonnet

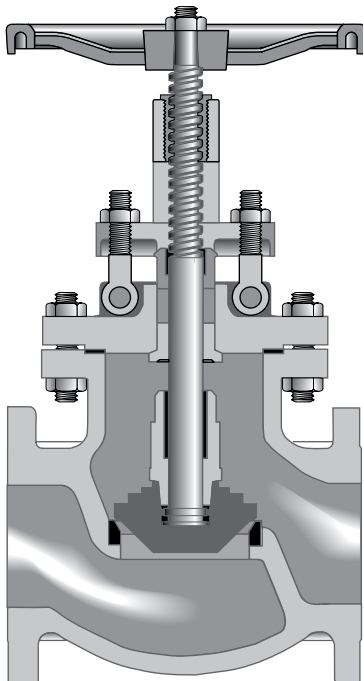
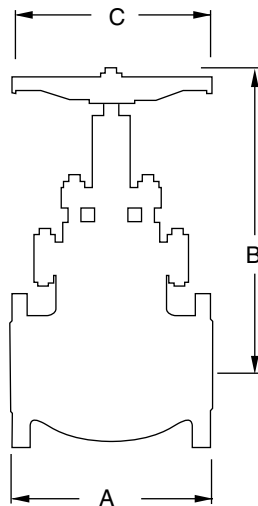

Figure 143
Globe, Flanged
Figure 143½
Globe, Butt Weld

Size Range:
2 through 12 inches
(50 - 300 mm)

Pressure Temperature Rating
Carbon Steel
ASTM A216 Grade WCB
285 psi @ -20°F to 100°F
(20 bar @ -28°C to 37°C)



Industry Standards

Steel Valves	ASME B16.34
Face-to-Face/End-to-End	ASME B16.10
Flange Dimensions	ASME B16.5
Weld End	ASME B.16.25
Testing	API 598

Material of Construction*

Description	Material
Body	WCB
Bonnet	WCB
Seat Rings	Hardfaced
Disc	13% CR Overlay
Stem	410 SS
Packing	Graphite
Bonnet Gasket	Corrugated Soft Steel or Steel/ Stainless Steel w/Graphite
Back Seat	410 SS
Disc Stem Nut	410 SS
Disc Washer	Carbon Steel
Gland	410 SS
Gland Flange	WCB
Eye Bolt	Steel
Eye Bolt Nuts	A563 Gr. A or O
Pins	-
Bonnet Studs	A193 Gr. B7
Bonnet Nuts	A194 Gr. 2H
Handwheel	WCB
Handwheel Nut	A194 Gr. 2H
I.D. Tags	SS
I.D. Pins	Steel

NOTES:

*Standard construction: WCB-Trim 8, other options are available. Crane recommends the use of manual or powered gear assistance for sizes 6" and larger.

Dimensions and Weights

Inches (millimeters) - pounds (kilograms)

Valves	2 (50)	2 ½ (65)	3 (80)	4 (100)	6 (150)	8 (200)	10 (250)	12 (300)
A	8.00 (203)	8.50 (216)	9.50 (241)	11.50 (292)	16.00 (406)	19.50 (495)	24.50 (622)	27.50 (698)
B (Open)	14 (356)	16 (406)	16 (406)	19 (482)	21 (533)	24 (610)	29 (736)	40 (1016)
C	8 (203)	8 (203)	10 (254)	12 (304)	14 (355)	18 (457)	20 (508)	24 (610)
Wt. (143)	48 (21)	70 (31)	92 (41)	132 (59)	223 (101)	355 (161)	640 (290)	1100 (498)
Wt. (143½)	49 (22)	60 (27)	84 (38)	137 (62)	230 (104)	350 (158)	680 (308)	1190 (539)