

Class 150 • Threaded Cap • Brass/Bronze Disc • Threaded Ends

137 Swing Check Valve

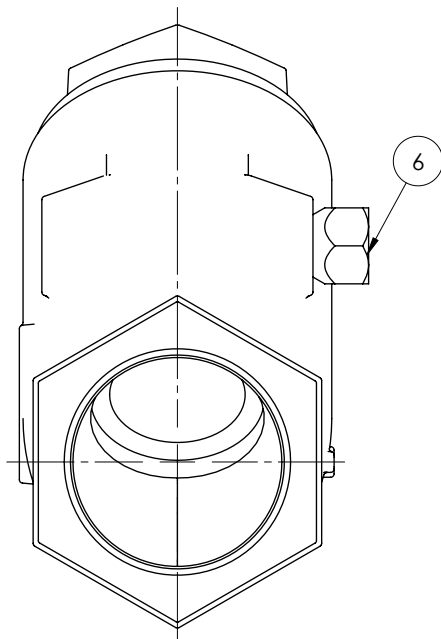
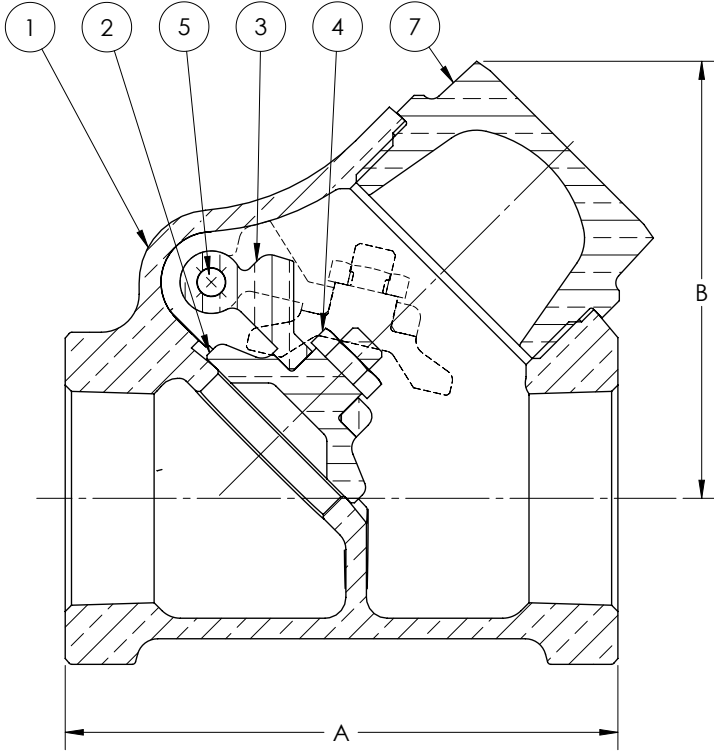

Materials of Construction

No.	Description	Material	ASTM Spec.
1	Body	(1/4" - 3/8") Bronze	B-62 C83600
		(1/2" - 3") Bronze	B-62 C83600
2	Disc	(1/4" - 3/4") Brass	B-16 H02
		(1" - 2") Bronze	B-61 C92200
		(2 1/2" - 3") Bronze	B-62 C83600
3	Hinge	Bronze	B-584 C87600
4	Lock Nut	Brass	B-16 H02
5	Hinge Pin	Stainless Steel	A-276 Type 304
6	Hinge Pin Plug	Brass	B-16 H02
7	Cap	Bronze	B-61 C92200

Caution: Not recommended for use with reciprocating pumps or air compressors in liquid or gas services. See page 8 for Pressure-Temperature Ratings.

Industry Standards
MSS SP-80, Type 3

Dimensions and Weights
Inches (millimeters) - Pounds (kilograms)

Valve Size	Dimensions		Wt.
	B	A	
1/4	1.49 (38)	2.14 (54)	0.50 (0.23)
	1.49 (38)	2.14 (54)	0.50 (0.23)
3/8	1.64 (42)	2.15 (55)	0.60 (0.27)
	1.92 (49)	2.71 (69)	1.00 (0.45)
1/2	2.52 (64)	3.18 (81)	1.50 (0.68)
	2.95 (75)	3.81 (97)	2.20 (1.00)
1 1/4	3.43 (87)	4.34 (110)	3.40 (1.55)
	4.19 (106)	5.11 (130)	5.40 (2.45)
2	5.04 (128)	6.12 (155)	9.00 (4.09)
	5.97 (152)	7.25 (184)	14.50 (6.59)